



ADVANCED TREATMENT Accessories (Recirculation Devices)

ATS-GRD-100/50/50

Features

- Gravity Recirculation Device provides 50% recirculation
- During times of no flow, float valve changes recirculation rate to 100%
- Installed directly over pump tank opening
- Ideal for use on vacation or weekend homes
- Float valve is field adjustable for proper placement

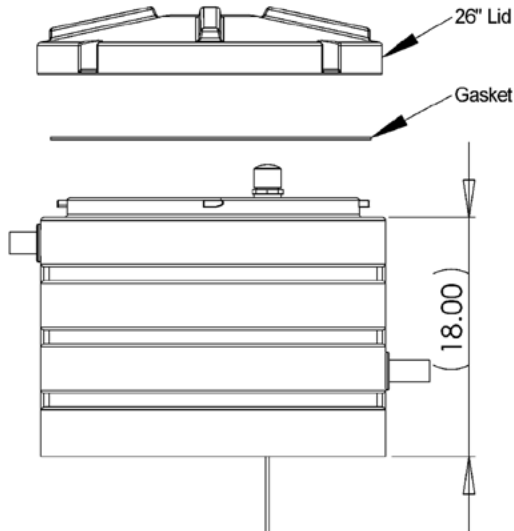
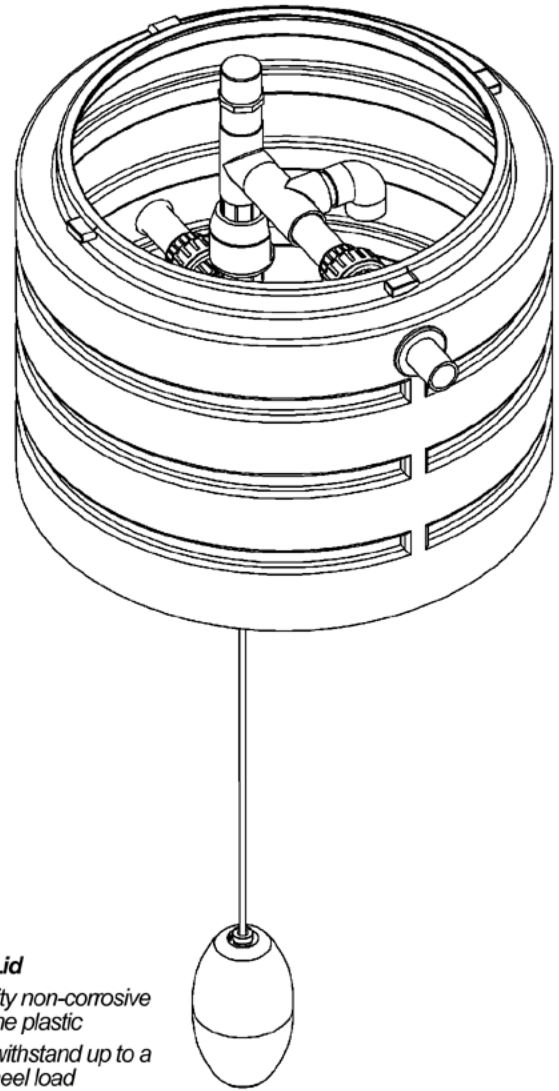

Rod length will vary with tank or filtered pump vault depth

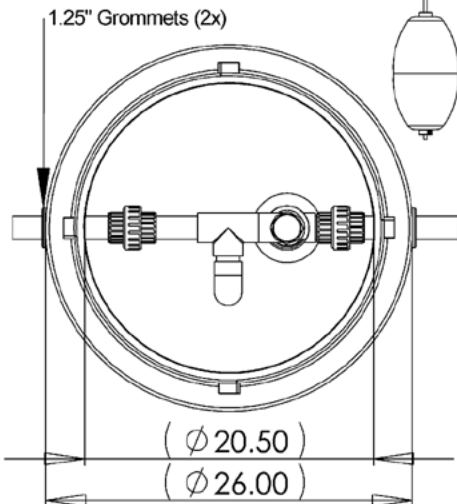

Materials

Riser and Lid

- High density non-corrosive polyethylene plastic
- Tested to withstand up to a 2500 lb wheel load
- Neoprene gasket
- Stainless steel tamper resistant hardware
- 26" diameter lid

Effluent Discharge Assembly

- 1.25" Sch 40 PVC Pipe
- Rubber Grommets

Float Valve Assembly

- 60" Stainless steel rod
- Polypropylene float

Warranty for Defects in Material and Workmanship

- Riser and Lid - 2 Years
- Effluent Discharge Assembly - 2 Years
- Float Valve Assembly - 2 Years



P.O. Box 1520, Crestwood, Ky, 40014

Copyright 2006, Quanics Incorporated, All rights reserved
Product(s) covered by one or more U.S. and/or International patents. Other U.S. and International patents may be pending.