

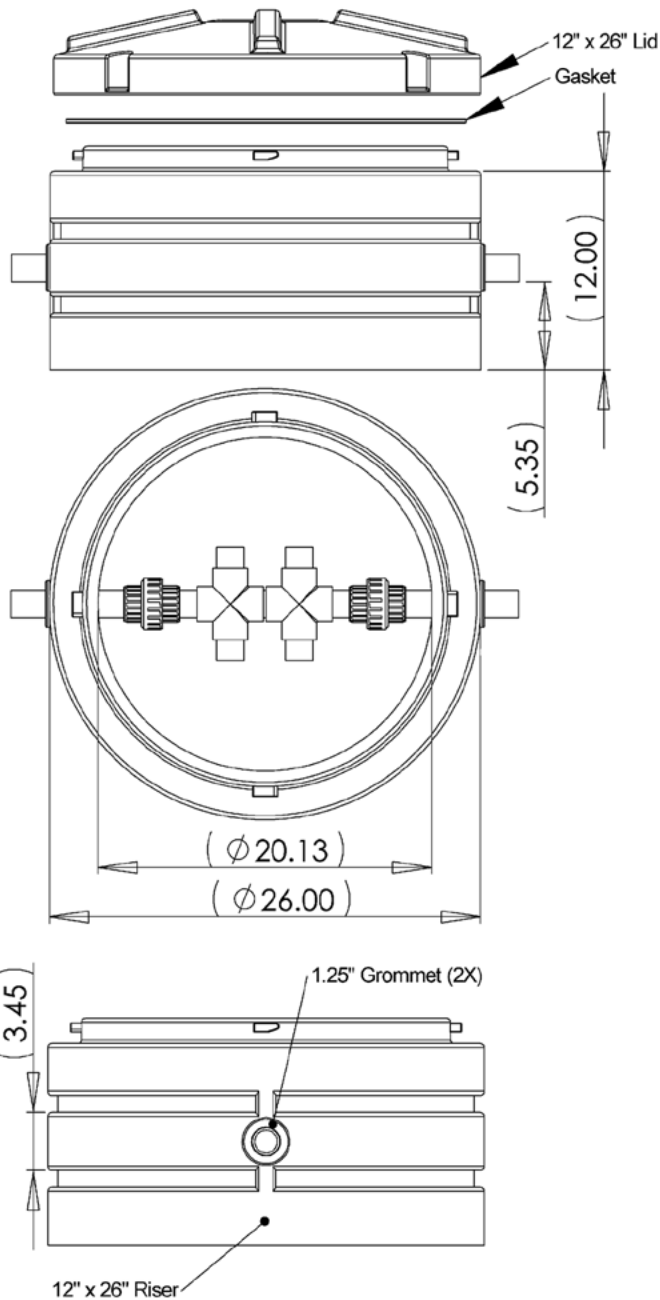

ADVANCED TREATMENT
Accessories (Recirculation Devices)
ATS-GRD-80/20

Features

- Gravity Recirculation Device provides 80% recirculation
- Installed directly over recirculation tank opening
- Extra extension risers may be added to bring up to grade
- Includes two quick disconnects for removal

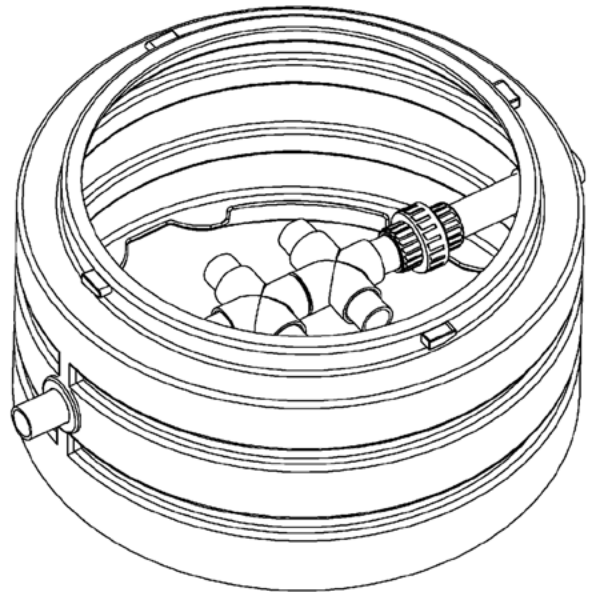

Materials

Riser and Lid

- High density non-corrosive polyethylene plastic
- Tested to withstand up to a 2500 lb wheel load
- Neoprene gasket
- Stainless steel tamper resistant hardware
- 26" diameter lid

Effluent Discharge Assembly

- 1.25" Sch 40 PVC Pipe
- Rubber Grommets

Warranty for Defects in Material and Workmanship

- Riser and Lid - 2 Years
- Effluent Discharge Assembly - 2 Years



P.O. Box 1520, Crestwood, Ky, 40014

Copyright 2006, Quanics Incorporated, All rights reserved
 Product(s) covered by one or more U.S. and/or international patents. Other U.S. and international patents may be pending.