



## STEP Systems ZEUS STEP Packages

### ZS-200

#### Features

- Designed for higher performance onsite systems where high heads are required
- Includes all components for pump installation into either a primary tank or pump tank
- Includes a 10, 20 or 30 gpm turbine effluent pump
- Additional risers may be added for deeper installations

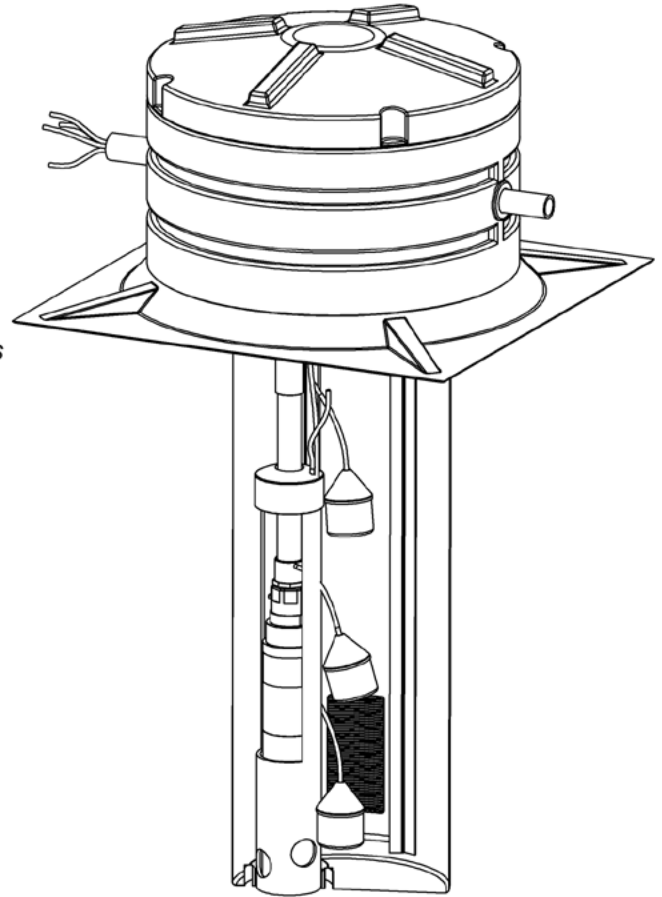
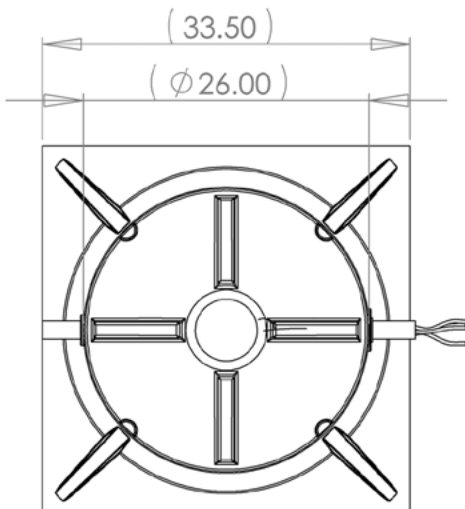
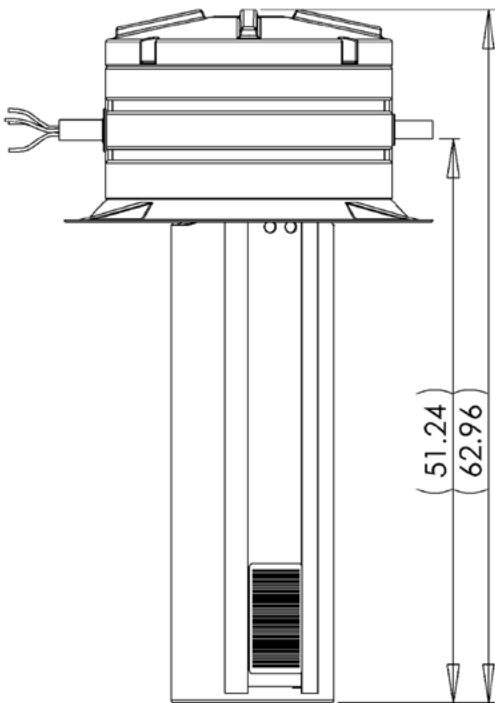

#### Components

- FPV-H44-4:** 44" Filtered Pump Vault with 2 filter plates
- RB-R-26x2:** 26" x 2" Retrofit Tank Adapter
- RB-R-26x12:** 26" x 12" Riser
- RB-L-26:** 26" Lid
- P-TE-10/20/30:** 1/2 hp, 10, 20 or 30 gpm Turbine Effluent Pump
- PDS-TD-1.25:** 1.25" Turbine Discharge
- PDS-GT-1.25:** 1.25" Rubber Grommet
- AC-JSB-4:** Junction Splice Box with 4 Cord Grips
- AC-CP-S-C:** Simplex Contactor Control Panel
- PDS-GT-1.50 :** 1.5" Rubber Grommet

#### Warranty for Defects in Material and Workmanship

- Pump - 3 Years
- Alarms/Controls - 3 Years
- Risers and Lids - 2 Years
- Filtered Vault - 10 Years
- All other components - 2 Years



P.O. Box 1520, Crestwood, Ky, 40014

Copyright 2006, Quanics Incorporated, All rights reserved  
Product(s) covered by one or more U.S. and/or international patents. Other U.S. and international patents may be pending.