



STEP Systems Pumps (Sewage)

P-SS-12T

Features

- Class 30 cast iron construction
- Carbon/Ceramic mechanical seal
- Piggy-back style float for automatic or manual operation
- Oil-filled motor with automatic reset overload provides safe operation
- Ball bearing construction for long life

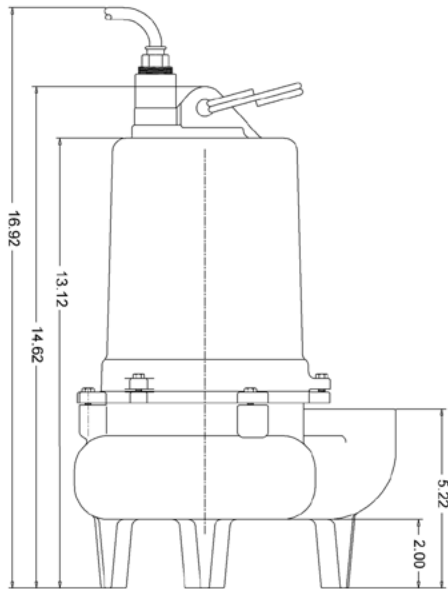
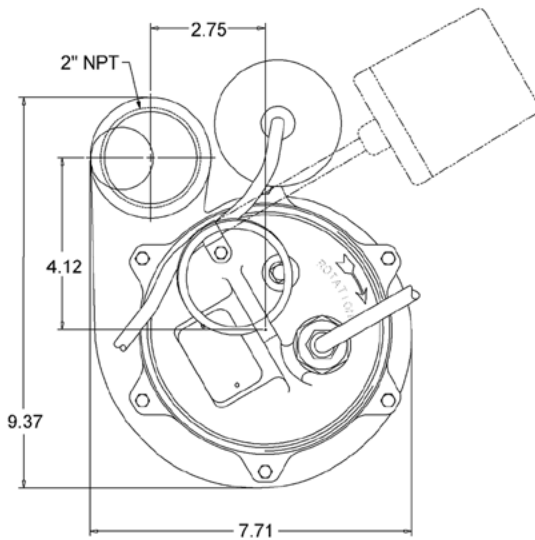

Specifications

Capacities: To 130 GPM

Heads: To 23 FT

Motor: 1/2 HP (1550 RPM); Shaded pole with thermal overload

Electrical: 115V, 13.0FLA, 1Ph, 60Hz

Operation: Tethered float

Impeller: Thermoplastic, vortex type

Solids Handling: 2" (50.8mm)

Power Cord: 10' (3M) or 20' (6M) 16-3, SJTW-A/SJTW

Discharge: 2"

Warranty for Defects in Material and Workmanship

- All components - 3 Years

AutoCad R-14 dwg files at www.zabelzone.com/autocad.htm

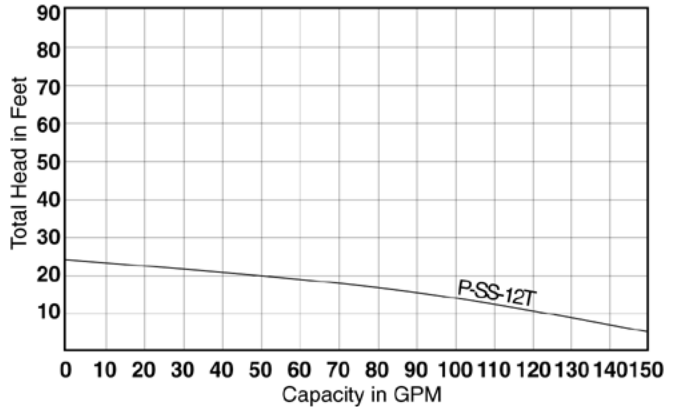

P.O. Box 1520, Crestwood, Ky, 40014

Copyright 2006, Quanics Incorporated, All rights reserved
Product(s) covered by one or more U.S. and/or international patents. Other U.S. and international patents may be pending.