



P.O. BOX 1520  
6244 OLD LAGRANGE ROAD  
CRESTWOOD, KY 40014  
[www.quanics.net](http://www.quanics.net)

PHONE: (502) 992-8200  
1-877-QUANICS  
FAX: (502) 992-8201

CLASS I / NSF STD 40  
WASTEWATER TREATMENT SYSTEM



**HOMEOWNERS MANUAL**

FIXED FILM MEDIA  
WASTEWATER TREATMENT SYSTEMS

## INTRODUCTION

**QUANICS™** is committed to becoming the best water solutions problem solver in the world. We promise to provide complete engineered water solutions using the latest technology and best products. We will provide the best technical assistance and customer service available and we will always deliver more than we promise.

In our quest to serve our market, we do not view a technology as the one and only option, but rather look to develop a wide variety of technologies that the engineer and/or end user can tailor to their individual application. Along this line, we are proud to introduce two NSF Certified treatment systems, SCAT® **AeroCell®** and SCAT **Bio-COIR™**.

Both systems operate as fixed-film media filters to treat wastewater. The patented SCAT delivery system is the same for each system only the media is different. Each media type has its own unique properties and both have been tested and listed under NSF International Standard 40 Class 1 requirements. Both systems have also been demonstrated to significantly reduce total nitrogen. The following manual will explain the differences and similarities of each system. Before reading this manual determine which system you are currently utilizing by examining the data plate attached to the system lid. Each system will be identified by name "**Bio-COIR**" or "**AeroCell**".

This manual covers the following model numbers.

<b>AeroCell Model #'s</b>	<b>Bio-COIR Model #'s</b>
ATS-SCAT-8-AC-C500	ATS-SCAT-8-BC-C500
ATS-SCAT-86-AC-C750	ATS-SCAT-86-BC-C750
ATS-SCAT-88-AC-C1000	ATS-SCAT-88-BC-C1000
ATS-SCAT-886-AC-C1250	ATS-SCAT-886-BC-C1250
ATS-SCAT-888-AC-C1500	ATS-SCAT-888-BC-C1500

The dealer who installs your wastewater treatment system is responsible for completing and submitting the warranty sheet found in this manual to activate your warranty.

We are eager to assist you with any questions or problems. Please contact **QUANICS** at 1-877-QUANICS to request assistance.

## PROCESS DESCRIPTION

The **QUANICS AeroCell & Bio-COIR** are individual wastewater treatment systems utilizing fixed film media. The module(s) consist of a fiberglass tank(s) containing a pre-determined amount of media. Effluent is sprayed over the media utilizing specialized spray nozzles. This patented delivery system evenly distributes wastewater to achieve the desired treatment levels.

The **AeroCell** utilizes open cell foam media. The foam has a high porosity, large surface area and ease of microbial attachment that allows for loading rates up to ten times that of sand. Open cell foam has a fifteen year track

record of treating wastewater to the highest quality treatment levels. The application rates for the **AeroCell**® system have been carefully selected to provide optimal treatment and performance in a long lasting media.

The **Bio-COIR**™ utilizes a patent pending **Bio-COIR** media for treatment. The **Bio-COIR** media is composed of fibers that constitutes the thick mesocarp, or husk, of the coconut fruit. The long fibers are used for ropes, door mats etc, leaving pith tissue and short to medium length fibers as a waste which has accumulated in heaps in many third world countries. The short to medium length fibers used in **Bio-COIR** are a lingocellulosic material. The high lignin content of these fibers results in a more durable material than other natural medias. The high lignin content of 45.84% also results in a slower degradation of the media and assures that excellent water/air ratio is maintained over a longer period of time.

In both **AeroCell & Bio-COIR** systems, pretreatment of the wastewater occurs through the use of a septic tank equipped with a Zabel® A300 series effluent filter on the outlet. The pretreated wastewater then moves into a dosing tank where an effluent pump doses the wastewater to the treatment module(s). The dosing of effluent occurs in short frequent doses over a 24-hour period utilizing a timed dosed control panel. Effluent is sprayed over the media through the use of specially designed helical spray nozzles that provide uniform distribution of the effluent over the entire surface area.

Once sprayed, the effluent moves via gravity down through the media where it is allowed to come into contact with beneficial microorganisms that serve to treat the effluent to NSF International Standard 40 Class 1 requirements. After passing through the full depth of media the effluent travels to the **QUANICS**™ ATS-GRD-100/80/20 recirculation device. The recirculation device splits the flow and discharges 80% back into the treatment stream and 20% to the final disposal point. In periods of low flow, 100% of the treated effluent discharges back into the treatment stream.

## OPERATING INSTRUCTIONS

The **AeroCell & Bio-COIR** systems have been designed and built to provide efficient, dependable and reliable service. However, as with any individual wastewater treatment system, routine periodic service is required. When proper preventive maintenance is performed, these systems will operate at designed performance levels giving years of satisfactory treatment of domestic wastewater.

The local dealer from whom you purchased your **AeroCell** or **Bio-COIR** system will perform all routine inspections for the first 2 years from the original date of installation. At the time of inspection, the system will be checked for proper operation. If a problem exists, service will be performed at no charge to the owner unless the required maintenance is not warranty related. At the end of the 2 year initial service period, your local dealer will make available a continuing service policy. Call **QUANICS** at 1-877-**QUANICS** for more information.

The treatment system electrical controls are located within the control panel. The control panel enclosure is equipped with an alarm beacon and an audible horn alarm. See "System Troubleshooting Guide" in this manual for

instructions on what to do if the alarm beacon or horn comes on. After a power failure, if an alarm remains on for more than 30 minutes you should call the local dealer immediately.

Your **AeroCell**® or **Bio-COIR**™ system will handle all domestic wastewater from your home. By the term wastewater we are referring to rapidly biodegradable material. To keep maintenance at a minimum level and to prevent the system from malfunctioning, the following guidelines need to be followed:

- \* Since aerobic bacteria are responsible for treating the wastewater, inorganic or non rapidly biodegradable materials should not be put into the system. Examples of improper items are: plastic products, rubber products, sanitary napkins or tampons, washcloths, cigarette butts, coffee grounds, eggshells, matches, or other non-biodegradable objects.
- \* Do not dispose of cooking grease or large amounts of oil into system; instead pour it into a container and dispose of it properly.
- \* To minimize pump-out frequency, limit use of garbage disposals.
- \* Lint from lint catchers, hair, etc., should be disposed in the trash and not washed down the drain.
- \* Water softener backwash should not be routed through the system. Another source of disposal should be used.
- \* Diapers can be rinsed out in the toilet; however, do not flush cloth or disposable diapers down the toilet.
- \* Large amounts of harsh chemicals, high-sudsing detergents, disinfectants or any substance that kills bacteria must not be discharged into the system.
- \* The system will not perform to its fullest capabilities if volumetric overload is allowed to occur. This occurs whenever excessive water, above the designed flow rate, is allowed into the system. Excessive water use or leaking plumbing fixtures may cause this condition.

Other than for the mechanical and structural workings of the system itself, **QUANICS**™ is not responsible for the in-field operation of a system. The proper operation of this or any other individual wastewater system depends upon proper organic and hydraulic loading of the system. We cannot control the loading and thereby cannot control the amount of harmful substances that may be discharged into the system. Only the users of a system can control what enters the unit.

## **MAINTENANCE SCHEDULE**

Normal maintenance **every 6 months** on your **AeroCell & Bio-COIR** system will include:

- a. Maintaining effluent filter
- b. Maintaining filtered pump vault
- c. Proper pump operation
- d. Inspecting and testing system alarms
- e. Check spray nozzles for debris
- f. Inspect septic/dosing tanks for pump out

**Note 1:** Replacement parts can be obtained from your local dealer or **QUANICS**.

**Note 2:** Pumping the septic/dosing tanks is usually necessary every 2 to 6 years; however, there is no set time because loadings vary from household

to household. Access to the tank(s) is accomplished through the normal 26-inch access opening, which is at surface grade. The tank(s) should be washed and cleaned while it is being pumped. The waste from the system must be disposed of in compliance with all federal, state, and local laws.

**Warning** - Caution must be used when pumping water from any tank.

Hydraulic displacement and tank flotation may occur whenever water and solids are removed from the tank when high groundwater conditions exist. Any source of water in the soil around the system installation could cause the tank to float. Water sources may include rainfall, springs, creeks, bayous, rivers, lakes, and coastal areas. Proper precautions are therefore required to prevent tank flotation due to hydraulic displacement.

These precautions include, but are not limited to, the following:

- \* System locations - choose a site that will minimize possible groundwater saturation. Consider seasonal water table and soil conditions in the area of installation. Do not locate the system in a low spot in the ground where water tends to pool or at the edge of any natural body of water. If such a location cannot be avoided, call **QUANICS™** (1-877-**QUANICS**) for technical advice.
- \* It is recommended that you pump the tank during dry seasons only. However, if tank must be pumped during the wet season, watch for upward movement of the tank while pumping is being done. If upward movement is detected during pumping, immediately stop pumping water out of the tank and refill the tank to stop flotation. Each site must be evaluated on a case-by-case basis to determine the best time to remove water from the tank and prevent flotation.

## **COMPLIANCE WITH LAW**

All permits and approvals from the local regulatory body should first be obtained before the treatment system is installed. All state and federal laws should be obeyed in areas that do not have local control over environmental activities.

It is important to remember that each state has independent regulations and guidelines for the installation of this treatment system and any auxiliary equipment that may accompany the system. You are responsible for installing this system and associated ancillary items in accordance with all regulations and guidelines as they are issued in your respective state. If such items as pretreatment tanks, storage or equalization tanks, chlorination facilities, pump tanks, etc. are required by law, then it is the intent of this company to comply with the letter of the law.

**QUANICS** through its years of experience recognizes the advantages of every component of the wastewater treatment system. Because of this experience we can recommend to you those parts of a system that are beneficial to the overall system and those that are also compliant with the laws in your

state. Please contact us for assistance or inquiries at 1-877-QUANICS.

## **START-UP PROCEDURE**

Once all installation connections are completed, remove the four spray nozzles by un-clamping them from the discharge assembly. Turn on the pump to flush any debris from inside the discharge assembly. After flushing, turn off the pump and reinstall by locating the nozzle over the discharge hole and sliding the clamp over the top of the discharge assembly. Turn the pump back on to pressurize the system to check for leaks and set the pressure gauge mounted on the nozzle discharge assembly to 5-8 psi using the ball valve attached to the assembly. Place the control panel Pump On switch in the auto position.

If the system is to be used intermittently or extended periods of non use are anticipated, no special procedures are required. The system is equipped with a timer, floats, and recirculation device that will keep the system operational. If any mechanical or electrical problems are experienced when attempting startup, the owner should call the dealer for service and assistance.

## **SYSTEM TROUBLESHOOTING GUIDE**

The **AeroCell® & Bio-COIR™** systems have proven to be very effective and reliable in the treatment of domestic wastewater. The problems outlined here occur only in a very small percent of total installations. They can all be corrected and most can be prevented.

When calling for service, describe the problem in detail and determine the system age and service history from your records. You will need to provide the service technician with the model numbers of the treatment system. These are found on data plates on the lid of the treatment module.

If routine servicing does not solve the problem, additional steps/maintenance, repair and/or replacement of defective parts may be required. Your service representative should perform these system inspections to assure adequate and proper operation of the wastewater treatment system.

### **1. Proper Installation Check**

Inspect system to verify that the treatment system is installed properly and is not damaged. The system should be level and internal components should be in their proper place and working order. High water level in the system can adversely affect performance.

### **2. Proper Treatment Check**

After determining that the system is installed properly and is not damaged, inspect the operation and maintenance status to determine if the system is performing correctly.

To do this a technician takes a grab sample of the effluent. This is tested for Total Suspended Solids (TSS) and Biochemical Oxygen Demand (BOD). The results should be within the performance guidelines outlined by NSF Standard 40 for Class 1 effluent. Adjustment and repairs to the system will be made as required by following factory recommended guidelines. Corrections to the system by a qualified service technician can keep the system operating properly.

### 3. Alarm System Check

The alarm supplied with this system provides the owner with a secure, reliable, dependable, and economical means of notification for high water levels. This alarm needs to be inspected and tested during each system operation and maintenance site visit.

The outside face of the control panel enclosure is equipped with visible and audible alarms to alert you of high-level conditions. If the alarms are activated on the control panel, a service technician should be called to determine the cause and make corrections. To silence the horn alarm while waiting for the service technician to arrive, locate the switch on outside of face of the control panel enclosure labeled "normal/silence" and push it into the "silence" (right) position. The alarm beacon will remain illuminated until alarm condition is solved.

If you exceed the system's designed daily flow rate (due to having house guests, doing multiple loads of laundry, etc.) the storage capacity of the pump/holding tank can be exceeded, activating audible and visible alarms. This system is equipped with a timer override function that should allow the system to run longer and alleviate any alarm condition. If the alarms are activated, silence the horn alarm by locating the switch on outside face of the control panel enclosure labeled "normal/silence" and pushing it to the "silence" (right) position. The alarm beacon will remain illuminated until alarm condition is solved. If excess water use continues, this problem could occur repeatedly.

### 4. Check to Determine Other Tanks Need Pumping

High solids level in other tanks can cause improper functioning of the treatment system. Inspection and service, as needed, should be performed a minimum of every 6 months.

## **SAFETY**

As raw wastewater may and usually does contain some level of unsafe microorganisms, proper respect and care must be given to safety. Whenever you come into contact with raw sewage, do not fear the contact, but do take proper precautions to avoid potential danger.

Follow these simple safety precautions whenever exposed to wastewater:

- \* Wear disposable rubber gloves when handling wastewater contaminated items.
- \* Always wash with soap and water after handling wastewater contaminated items. The use of good bactericide soap is strongly recommended.
- \* Always dispose of scum, rags, trash, debris, or soiled material in a proper waste container.
- \* If a wastewater spill or leak occurs in a yard, flush area with plenty of clean water and disinfect. If a spill or leak occurs in the house, clean with a dilute solution of bleach.
- \* Protect any injury, wound, open cut, etc. from exposure to wastewater. Prevention is always better and easier than curing a disease.
- \* If an illness or disease is suspected to have come from exposure to sewage, get proper medical attention immediately. There are some serious diseases

that could be transmitted by contact with raw sewage - take the proper precautions and be safe!

## LIMITED WARRANTY

**QUANICS™**, herein identified as **QUANICS**, warrants each **AeroCell® & Bio-COIR™** wastewater treatment system to be free from defects in material and workmanship for a period of two (2) years from the date of installation by an authorized Dealer for the end user when properly registered with **QUANICS**. The sole obligation under this warranty is as follows: **QUANICS** shall fulfill this warranty by replacing or exchanging any component part, FOB factory that in **QUANICS'** judgment shows evidence of defects, provided said component part has been paid for and is returned through an authorized Dealer, transportation prepaid. The Limited Warranty does not make any provision for an informal dispute settlement arrangement.

The warranty does not cover **QUANICS** wastewater treatment systems and related components that have flooded, by external means, or that have been disassembled by unauthorized person, improperly installed, subjected to external damage or damage due to altered or improper wiring or overload protection.

Recommendations for special applications will be based upon the best available expertise of **QUANICS** and published industry information. Such recommendations do not constitute a warranty of satisfactory performance.

No warranty is made as to the field performance of any systems. The Limited Warranty applies to the systems and does not include any portion of the plumbing, drainage, house wiring or installation of the treatment systems. Accessories supplied by **QUANICS**, but manufactured by others, are warranted for a period of two (2) years. In no event shall **QUANICS** be responsible for delay or damages of any kind or character resulting from, or caused directly or indirectly by, defective components or materials manufactured by others.

The Limited Warranty extends to the end user of this product. The end user is defined as the purchaser who first has the system installed, or in the case of the system designed for non-permanent installation, the purchaser who first uses the system. It is the end user's obligation to make known to any other consumer the terms and conditions of this Limited Warranty.

**QUANICS** reserves the right to revise, change, or modify the construction and design of the **QUANICS** aerobic wastewater treatment system, or any component part or parts thereof, without incurring any obligations to make such changes or modifications in previously sold equipment. **QUANICS** also reserves the right, in making replacements of component parts under this warranty, to furnish a component part, which, in its judgment, is equivalent to the part replaced. This warranty is a Limited Warranty. No claim of any nature shall be made against **QUANICS** unless and until the end user, or their legal representative, notifies **QUANICS**, in writing of the defect complained of and delivers the product and /or defective part(s), freight prepaid, to **QUANICS** or an authorized **QUANICS** dealer.

# 500 GPD AeroCell® System

www.quanics.net/autocad.htm

ZONE	REV.	DESCRIPTION	DATE	APPROVED

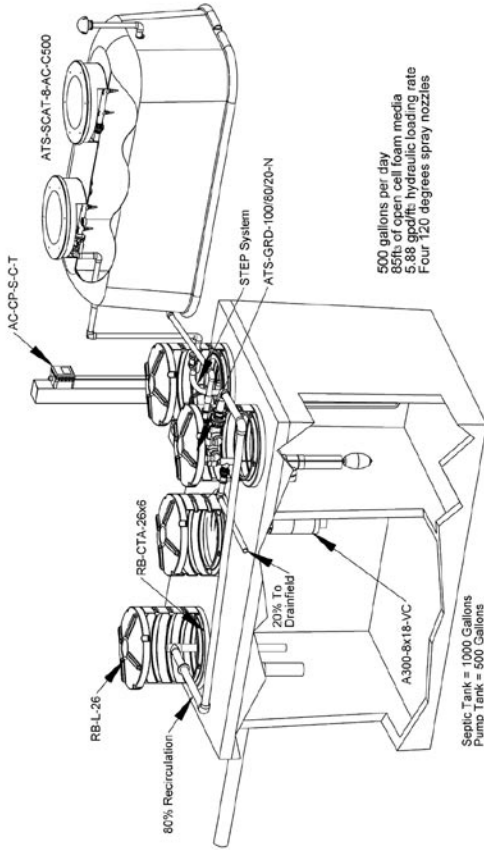

Septic Tank = 1000 Gallons  
 Pump Tank = 500 Gallons  
 The septic tank shall have a minimum L:W ratio of equal to or greater than one.

- Parts included:
- ATS-SCAT-8-AC-C500
  - A300-8x18-VC
  - FPV-H44-4
  - P-SE-13T
  - PPS-GT-1-5
  - PDS-GT-1-25
  - PDS-GT-1-5 (2x)
  - AC-FT-3
  - AC-SE-4-CT
  - AC-SE-4-T
  - ATS-GRD-100/80/20-N
  - RB-CTA-26x6 (4x)
  - RB-R-26x18 (3x)
  - RB-L-26 (3x)

Products covered by one or more U.S. and/or International patents may be pending.

QUANICS Incorporated		DATE	TIME	GROUP
DRAWN	TUJ	08/06/05		
CHECKED	BB	08/06/05		
ENCL APPR				
MG APPR				
G.A.				
COMMENTS				
DIMENSIONS ARE IN INCHES				
FRACTIONALS				
A=3/16" B=1/8" C=1/4" D=3/8" E=1/2" F=5/8" G=3/4" H=7/8" I=1" J=1 1/8" K=1 1/4" L=1 3/8" M=1 1/2" N=1 3/4" O=1 7/8" P=2" Q=2 1/8" R=2 1/4" S=2 3/8" T=2 1/2" U=2 3/4" V=2 7/8" W=3" X=3 1/8" Y=3 1/4" Z=3 3/8" AA=3 1/2" AB=3 3/4" AC=3 7/8" AD=4" AE=4 1/8" AF=4 1/4" AG=4 3/8" AH=4 1/2" AI=4 3/4" AJ=4 7/8" AK=5" AL=5 1/8" AM=5 1/4" AN=5 3/8" AO=5 1/2" AP=5 3/4" AQ=5 7/8" AR=6" AS=6 1/8" AT=6 1/4" AU=6 3/8" AV=6 1/2" AW=6 3/4" AX=6 7/8" AY=7" AZ=7 1/8" BA=7 1/4" BB=7 3/8" BC=7 1/2" BD=7 3/4" BE=7 7/8" BF=8" BG=8 1/8" BH=8 1/4" BI=8 3/8" BJ=8 1/2" BK=8 3/4" BL=8 7/8" BM=9" BN=9 1/8" BO=9 1/4" BP=9 3/8" BQ=9 1/2" BR=9 3/4" BS=9 7/8" BT=10" BU=10 1/8" BV=10 1/4" BW=10 3/8" BX=10 1/2" BY=10 3/4" BZ=10 7/8" CA=11" CB=11 1/8" CC=11 1/4" CD=11 3/8" CE=11 1/2" CF=11 3/4" CG=11 7/8" CH=12" CI=12 1/8" CJ=12 1/4" CK=12 3/8" CL=12 1/2" CM=12 3/4" CN=12 7/8" CO=13" CP=13 1/8" CQ=13 1/4" CR=13 3/8" CS=13 1/2" CT=13 3/4" CU=13 7/8" CV=14" CW=14 1/8" CX=14 1/4" CY=14 3/8" CZ=14 1/2" DA=14 3/4" DB=14 7/8" DC=15" DD=15 1/8" DE=15 1/4" DF=15 3/8" DG=15 1/2" DH=15 3/4" DI=15 7/8" DJ=16" DK=16 1/8" DL=16 1/4" DM=16 3/8" DN=16 1/2" DO=16 3/4" DP=16 7/8" DQ=17" DR=17 1/8" DS=17 1/4" DT=17 3/8" DU=17 1/2" DV=17 3/4" DW=17 7/8" DX=18" DY=18 1/8" DZ=18 1/4" EA=18 3/8" EB=18 1/2" EC=18 3/4" ED=18 7/8" EE=19" EF=19 1/8" EG=19 1/4" EH=19 3/8" EI=19 1/2" EJ=19 3/4" EK=19 7/8" EL=20" EM=20 1/8" EN=20 1/4" EO=20 3/8" EP=20 1/2" EQ=20 3/4" ER=20 7/8" ES=21" ET=21 1/8" EU=21 1/4" EV=21 3/8" EW=21 1/2" EX=21 3/4" EY=21 7/8" EZ=22" FA=22 1/8" FB=22 1/4" FC=22 3/8" FD=22 1/2" FE=22 3/4" FF=22 7/8" FG=23" FH=23 1/8" FI=23 1/4" FJ=23 3/8" FK=23 1/2" FL=23 3/4" FM=23 7/8" FN=24" FO=24 1/8" FP=24 1/4" FQ=24 3/8" FR=24 1/2" FS=24 3/4" FT=24 7/8" FU=25" FV=25 1/8" FW=25 1/4" FX=25 3/8" FY=25 1/2" FZ=25 3/4" GA=25 7/8" GB=26" GC=26 1/8" GD=26 1/4" GE=26 3/8" GF=26 1/2" GG=26 3/4" GH=26 7/8" GI=27" GJ=27 1/8" GK=27 1/4" GL=27 3/8" GM=27 1/2" GN=27 3/4" GO=27 7/8" GP=28" GQ=28 1/8" GR=28 1/4" GS=28 3/8" GT=28 1/2" GU=28 3/4" GV=28 7/8" GW=29" GX=29 1/8" GY=29 1/4" GZ=29 3/8" HA=29 1/2" HB=29 3/4" HC=29 7/8" HD=30" HE=30 1/8" HF=30 1/4" HG=30 3/8" HH=30 1/2" HI=30 3/4" HJ=30 7/8" HK=31" HL=31 1/8" HM=31 1/4" HN=31 3/8" HO=31 1/2" HP=31 3/4" HQ=31 7/8" HR=32" HS=32 1/8" HT=32 1/4" HU=32 3/8" HV=32 1/2" HW=32 3/4" HX=32 7/8" HY=33" HZ=33 1/8" IA=33 1/4" IB=33 3/8" IC=33 1/2" ID=33 3/4" IE=33 7/8" IF=34" IG=34 1/8" IH=34 1/4" II=34 3/8" IJ=34 1/2" IK=34 3/4" IL=34 7/8" IM=35" IN=35 1/8" IO=35 1/4" IP=35 3/8" IQ=35 1/2" IR=35 3/4" IS=35 7/8" IT=36" IU=36 1/8" IV=36 1/4" IW=36 3/8" IX=36 1/2" IY=36 3/4" IZ=36 7/8" JA=37" JB=37 1/8" JC=37 1/4" JD=37 3/8" JE=37 1/2" JF=37 3/4" JG=37 7/8" JH=38" JI=38 1/8" JJ=38 1/4" JK=38 3/8" JL=38 1/2" JM=38 3/4" JN=38 7/8" JO=39" JP=39 1/8" JQ=39 1/4" JR=39 3/8" JS=39 1/2" JT=39 3/4" JU=39 7/8" JV=40" JW=40 1/8" JX=40 1/4" JY=40 3/8" JZ=40 1/2" KA=40 3/4" KB=40 7/8" KC=41" KD=41 1/8" KE=41 1/4" KF=41 3/8" KG=41 1/2" KH=41 3/4" KI=41 7/8" KJ=42" KK=42 1/8" KL=42 1/4" KM=42 3/8" KN=42 1/2" KO=42 3/4" KP=42 7/8" KQ=43" KR=43 1/8" KS=43 1/4" KT=43 3/8" KU=43 1/2" KV=43 3/4" KW=43 7/8" KX=44" KY=44 1/8" KZ=44 1/4" LA=44 3/8" LB=44 1/2" LC=44 3/4" LD=44 7/8" LE=45" LF=45 1/8" LG=45 1/4" LH=45 3/8" LI=45 1/2" LJ=45 3/4" LK=45 7/8" LL=46" LM=46 1/8" LN=46 1/4" LO=46 3/8" LP=46 1/2" LQ=46 3/4" LR=46 7/8" LS=47" LT=47 1/8" LU=47 1/4" LV=47 3/8" LW=47 1/2" LX=47 3/4" LY=47 7/8" LZ=48" MA=48 1/8" MB=48 1/4" MC=48 3/8" MD=48 1/2" ME=48 3/4" MF=48 7/8" MG=49" MH=49 1/8" MI=49 1/4" MJ=49 3/8" MK=49 1/2" ML=49 3/4" MN=49 7/8" MO=50" MP=50 1/8" MQ=50 1/4" MR=50 3/8" MS=50 1/2" MT=50 3/4" MU=50 7/8" MV=51" MW=51 1/8" MX=51 1/4" MY=51 3/8" MZ=51 1/2" NA=51 3/4" NB=51 7/8" NC=52" ND=52 1/8" NE=52 1/4" NF=52 3/8" NG=52 1/2" NH=52 3/4" NI=52 7/8" NJ=53" NK=53 1/8" NL=53 1/4" NM=53 3/8" NN=53 1/2" NO=53 3/4" NP=53 7/8" NQ=54" NR=54 1/8" NS=54 1/4" NT=54 3/8" NU=54 1/2" NV=54 3/4" NW=54 7/8" NX=55" NY=55 1/8" NZ=55 1/4" OA=55 3/8" OB=55 1/2" OC=55 3/4" OD=55 7/8" OE=56" OF=56 1/8" OG=56 1/4" OH=56 3/8" OI=56 1/2" OJ=56 3/4" OK=56 7/8" OL=57" OM=57 1/8" ON=57 1/4" OO=57 3/8" OP=57 1/2" OQ=57 3/4" OR=57 7/8" OS=58" OT=58 1/8" OU=58 1/4" OV=58 3/8" OW=58 1/2" OX=58 3/4" OY=58 7/8" OZ=59" PA=59 1/4" PB=59 3/8" PC=59 1/2" PD=59 3/4" PE=59 7/8" PF=60" PG=60 1/8" PH=60 1/4" PI=60 3/8" PJ=60 1/2" PK=60 3/4" PL=60 7/8" PM=61" PN=61 1/8" PO=61 1/4" PP=61 3/8" PQ=61 1/2" PR=61 3/4" PS=61 7/8" PT=62" PU=62 1/8" PV=62 1/4" PW=62 3/8" PX=62 1/2" PY=62 3/4" PZ=62 7/8" QA=63" QB=63 1/8" QC=63 1/4" QD=63 3/8" QE=63 1/2" QF=63 3/4" QG=63 7/8" QH=64" QI=64 1/8" QJ=64 1/4" QK=64 3/8" QL=64 1/2" QM=64 3/4" QN=64 7/8" QO=65" QP=65 1/8" QQ=65 1/4" QR=65 3/8" QS=65 1/2" QT=65 3/4" QU=65 7/8" QV=66" QW=66 1/8" QX=66 1/4" QY=66 3/8" QZ=66 1/2" RA=66 3/4" RB=66 7/8" RC=67" RD=67 1/8" RE=67 1/4" RF=67 3/8" RG=67 1/2" RH=67 3/4" RI=67 7/8" RJ=68" RK=68 1/8" RL=68 1/4" RM=68 3/8" RN=68 1/2" RO=68 3/4" RP=68 7/8" RQ=69" RR=69 1/8" RS=69 1/4" RT=69 3/8" RU=69 1/2" RV=69 3/4" RW=69 7/8" RX=70" RY=70 1/8" RZ=70 1/4" SA=70 3/8" SB=70 1/2" SC=70 3/4" SD=70 7/8" SE=71" SF=71 1/8" SG=71 1/4" SH=71 3/8" SI=71 1/2" SJ=71 3/4" SK=71 7/8" SL=72" SM=72 1/8" SN=72 1/4" SO=72 3/8" SP=72 1/2" SQ=72 3/4" SR=72 7/8" SS=73" ST=73 1/8" SU=73 1/4" SV=73 3/8" SW=73 1/2" SX=73 3/4" SY=73 7/8" SZ=74" TA=74 1/4" TB=74 3/8" TC=74 1/2" TD=74 3/4" TE=74 7/8" TF=75" TG=75 1/8" TH=75 1/4" TI=75 3/8" TJ=75 1/2" TK=75 3/4" TL=75 7/8" TM=76" TN=76 1/8" TO=76 1/4" TP=76 3/8" TQ=76 1/2" TR=76 3/4" TS=76 7/8" TT=77" TU=77 1/8" TV=77 1/4" TV=77 3/8" TW=77 1/2" TX=77 3/4" TY=77 7/8" TZ=78" UA=78 1/4" UB=78 3/8" UC=78 1/2" UD=78 3/4" UE=78 7/8" UF=79" UG=79 1/8" UH=79 1/4" UI=79 3/8" UJ=79 1/2" UK=79 3/4" UL=79 7/8" UM=80" UN=80 1/8" UO=80 1/4" UP=80 3/8" UQ=80 1/2" UR=80 3/4" US=80 7/8" UT=81" UV=81 1/8" UV=81 1/4" UV=81 3/8" UV=81 1/2" UV=81 3/4" UV=81 7/8" UV=82" VA=82 1/4" VB=82 3/8" VC=82 1/2" VD=82 3/4" VE=82 7/8" VF=83" VG=83 1/8" VH=83 1/4" VI=83 3/8" VJ=83 1/2" VK=83 3/4" VL=83 7/8" VM=84" VN=84 1/8" VO=84 1/4" VP=84 3/8" VQ=84 1/2" VR=84 3/4" VS=84 7/8" VT=85" VU=85 1/8" VU=85 1/4" VU=85 3/8" VU=85 1/2" VU=85 3/4" VU=85 7/8" VU=86" WA=86 1/4" WB=86 3/8" WC=86 1/2" WD=86 3/4" WE=86 7/8" WF=87" WG=87 1/8" WH=87 1/4" WI=87 3/8" WJ=87 1/2" WK=87 3/4" WL=87 7/8" WM=88" WN=88 1/8" WO=88 1/4" WP=88 3/8" WQ=88 1/2" WR=88 3/4" WS=88 7/8" WT=89" WU=89 1/8" WU=89 1/4" WU=89 3/8" WU=89 1/2" WU=89 3/4" WU=89 7/8" WU=90" XA=90 1/4" XB=90 3/8" XC=90 1/2" XD=90 3/4" XE=90 7/8" XF=91" XG=91 1/8" XH=91 1/4" XI=91 3/8" XJ=91 1/2" XK=91 3/4" XL=91 7/8" XM=92" XN=92 1/8" XO=92 1/4" XP=92 3/8" XQ=92 1/2" XR=92 3/4" XS=92 7/8" XT=93" XU=93 1/8" XU=93 1/4" XU=93 3/8" XU=93 1/2" XU=93 3/4" XU=93 7/8" XU=94" YA=94 1/4" YB=94 3/8" YC=94 1/2" YD=94 3/4" YE=94 7/8" YF=95" YG=95 1/8" YH=95 1/4" YI=95 3/8" YJ=95 1/2" YK=95 3/4" YL=95 7/8" YM=96" YN=96 1/8" YO=96 1/4" YP=96 3/8" YQ=96 1/2" YR=96 3/4" YS=96 7/8" YT=97" YU=97 1/8" YU=97 1/4" YU=97 3/8" YU=97 1/2" YU=97 3/4" YU=97 7/8" YU=98" ZA=98 1/4" ZB=98 3/8" ZC=98 1/2" ZD=98 3/4" ZE=98 7/8" ZF=99" ZG=99 1/8" ZH=99 1/4" ZI=99 3/8" ZJ=99 1/2" ZK=99 3/4" ZL=99 7/8" ZM=100" ZN=100 1/8" ZO=100 1/4" ZP=100 3/8" ZQ=100 1/2" ZR=100 3/4" ZS=100 7/8" ZT=101" ZU=101 1/8" ZU=101 1/4" ZU=101 3/8" ZU=101 1/2" ZU=101 3/4" ZU=101 7/8" ZU=102				

SITE	DWG. NO.	REV.
A	ATS-SCAT-8-AC-C500	REV

# 500 GPD Bio-COIR™ System

www.quanics.net/autocad.htm

ZONE	REV.	REVISIONS DESCRIPTION	DATE	APPROVED

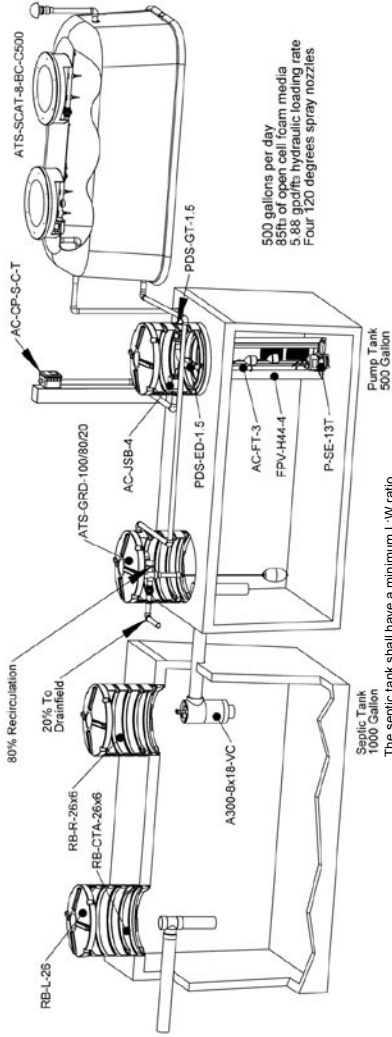

- Parts included:
- ATS-SCAT-8-BC-C500
  - A3000-8x18-VC
  - FPV-H44-4
  - P-SE-13T
  - AC-JSB-4
  - PDS-GT-1.5 (2x)
  - AC-FT-3
  - AC-CP-S-C-T
  - ATS-GRD-100/80/20
  - RB-CTA-26x6 (4x)
  - RB-R-26x6 (3x)
  - RB-L-26 (3x)

Product(s) covered by one or more U.S. and/or International patents may be pending.

NAME	DATE	THRU	DATE

DRAWN	CHECKED	ENG APPR.	MG APPR.	COMMENTS

DIVISIONS ARE IN INCHES:	SCALE
FRACTIONALS	1:50
ANGULARS/MACH:	---
TWO PLACE DECIMAL	---
THREE PLACE DECIMAL	---

MATERIAL	FINISH	USED ON	NEXT ASY	APPLICATION

SIZE	DWG. NO.	HYDRO.	SHEET OF 1
A	ATS-SCAT-8-BC-C500		

**QUANICS Incorporated**

**WARRANTY FORM TO GO HERE**

# Quanics

Engineering **Water** Solutions™

P.O. BOX 1520  
6244 OLD LAGRANGE ROAD  
CRESTWOOD, KY 40014  
[www.quanics.net](http://www.quanics.net)

PHONE: (502) 992-8200  
1-877-**QUANICS**  
FAX: (502) 992-8201

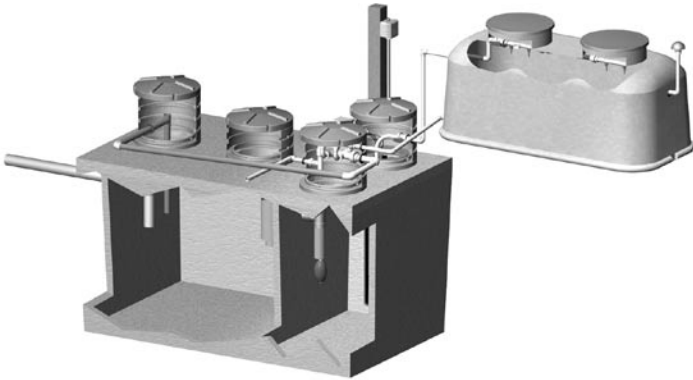

Treatment system service provider: