

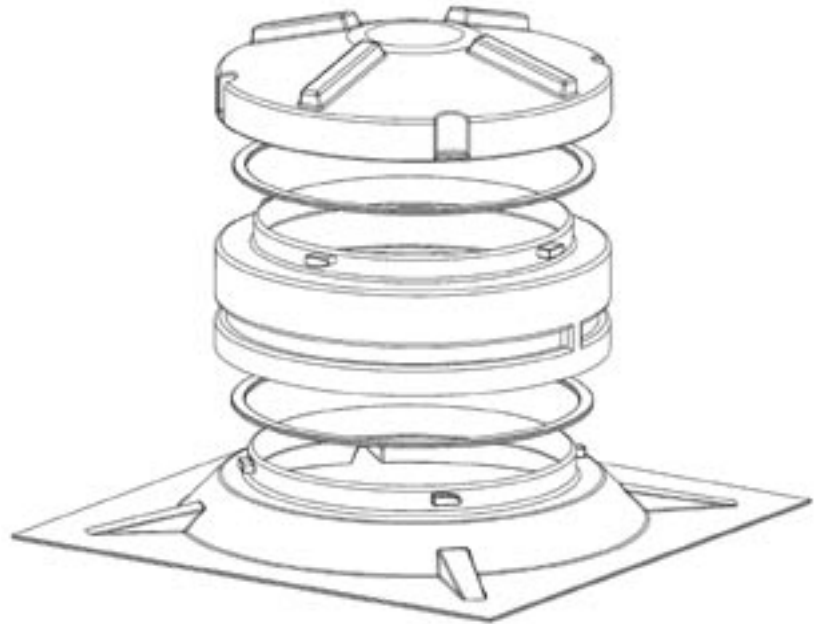

Replacement Parts Risers & Lids (26" Diameter)

Features:

- Patented 26" polyethylene risers
- All components include twist lock tabs
- Tamper resistant fasteners and fastening tool included with each lid
- Tested to withstand up to 2500 lb wheel load
- May be cast-in or retrofit to any concrete tank



RB-RTA-26x2
(Retrofit Tank Adapter)

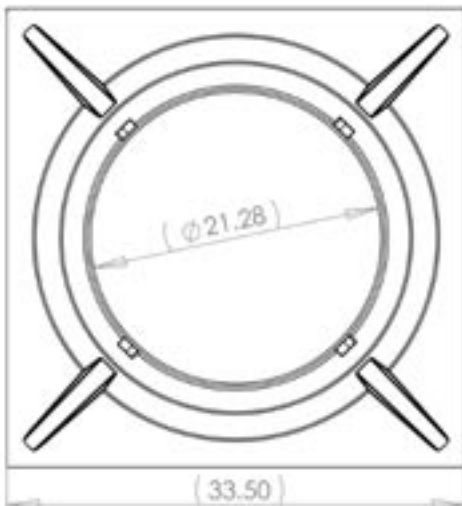
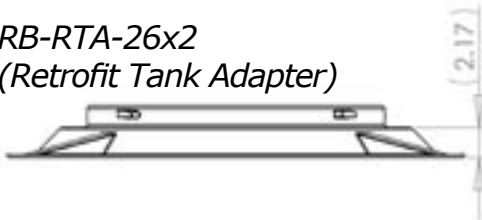

RB-L-26 (Lid)

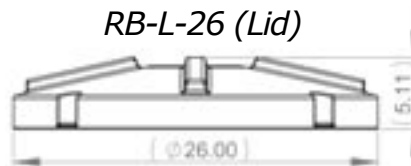

RB-R-26x6 (Riser)

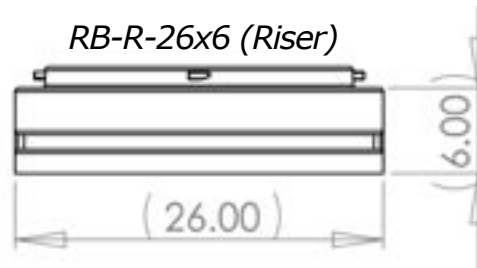

RB-R-26x12 (Riser)

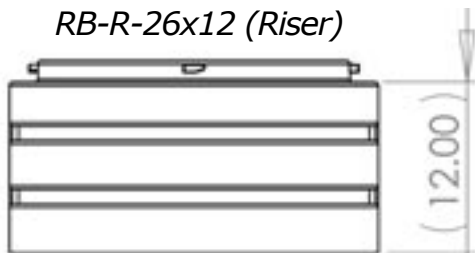

RB-R-26x18 (Riser)

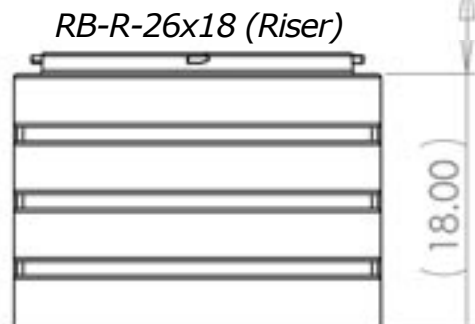

Materials:

Risers and Lids

- High density non-corrosive polyethylene plastic
- Stainless steel screws
- Neoprene gasket

Warranty for Defects in Material and Workmanship

- Risers and Lids - 2 Years

IMPORTANT:

- When adding risers together for deeper installations Zabel does not recommend exceeding a maximum depth of 48".
- Neoprene gaskets must be installed as per instructions
- To prevent unauthorized entry install all tamper resistant fasteners as per instructions

AutoCad R-14 dwg files at www.quanics.net

1-877-QUANICS - www.quanics.net

Quanics
Engineering Water Solutions™

© 2006, Quanics Inc. All rights reserved.
Product(s) covered by one or more U.S.
and/or International patents. Other U.S.
and International patents may be pending.

DOWNLOAD
AutoCAD
DRAWINGS



Replacement Parts Risers & Lids (26" Diameter)

Features:

- Patented 26" polyethylene risers
- All components include twist lock tabs
- Tamper resistant fasteners and fastening tool included with each lid
- Tested to withstand up to 2500 lb wheel load
- May be cast-in or retrofit to any concrete tank

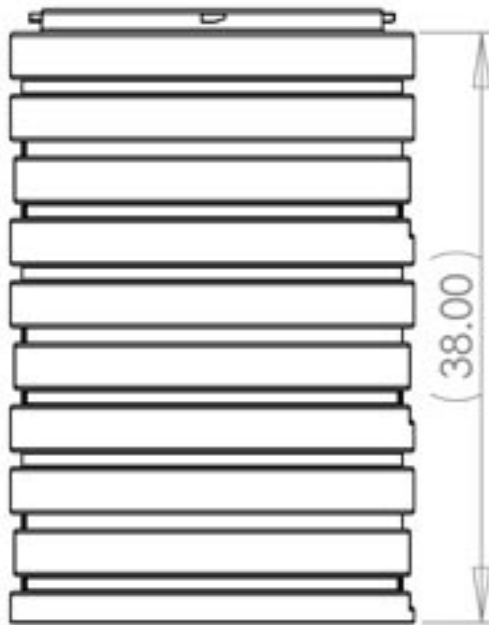
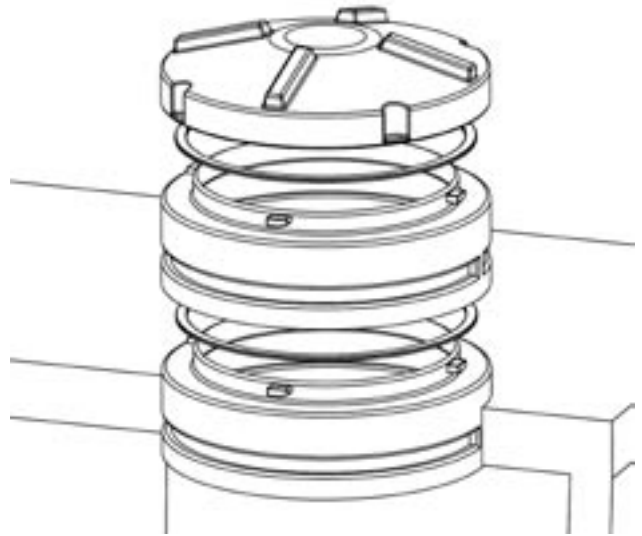

RB-R-26x18 (Riser)



RB-PTA-26x2
(Poly Tank Adapter)

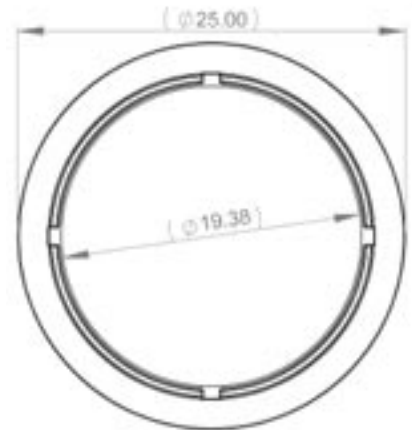
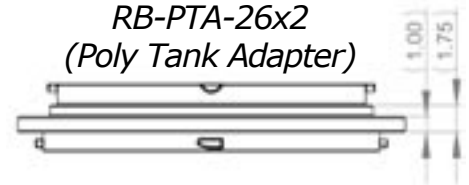

RB-CTA-26x6
(Cast-in Tank Adapter)

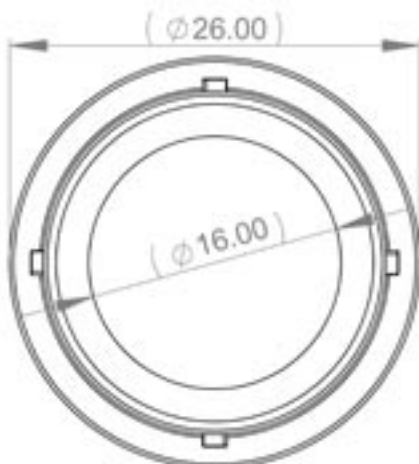

Materials:

Risers and Lids

- High density non-corrosive polyethylene plastic
- Stainless steel screws
- Neoprene gasket

Warranty for Defects in Material and Workmanship

- Risers and Lids - 2 Years

IMPORTANT:

- When adding risers together for deeper installations Zabel does not recommend exceeding a maximum depth of 48".
- Neoprene gaskets must be installed as per instructions
- To prevent unauthorized entry install all tamper resistant fasteners as per instructions

AutoCad R-14 dwg files at www.quanics.net

1-877-QUANICS - www.quanics.net

Quanics
Engineering Water Solutions™

© 2006, Quanics Inc. All rights reserved.
Product(s) covered by one or more U.S.
and/or International patents. Other U.S.
and International patents may be pending.

DOWNLOAD
AutoCAD
DRAWINGS