



Pressure Distribution Pressure Filter (1-1/2" & 2")

PDS-PF-1.5, PDS-PF-2.0

Models Include:

PDS-PF-1.5, PDS-PF-2.0

- Pressure Filter Body
- Screen Filter Cartridge
- Pressure Gauge
- Clear Basin
- Stainless Steel Safety Teather
- Drain Port
- 1-1/2" x 2" SCH 40 Slip/Slip Bushings (2x)

PDS-PF-1.5-AP, PDS-PF-2.0-AP (Assembly Package)

- Pressure Filter Body
- Screen Filter Cartridge
- Pressure Gauge
- Clear Basin
- Drain Port
- All plumbing parts (as seen at top right)

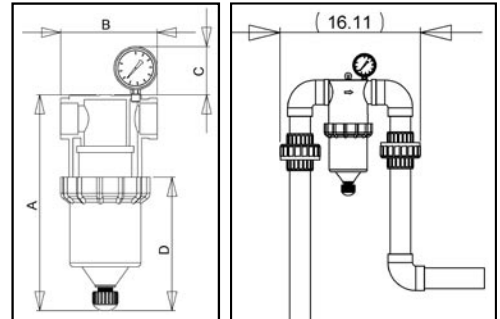
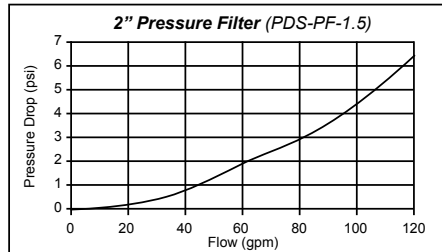
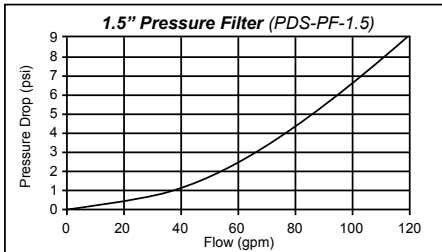
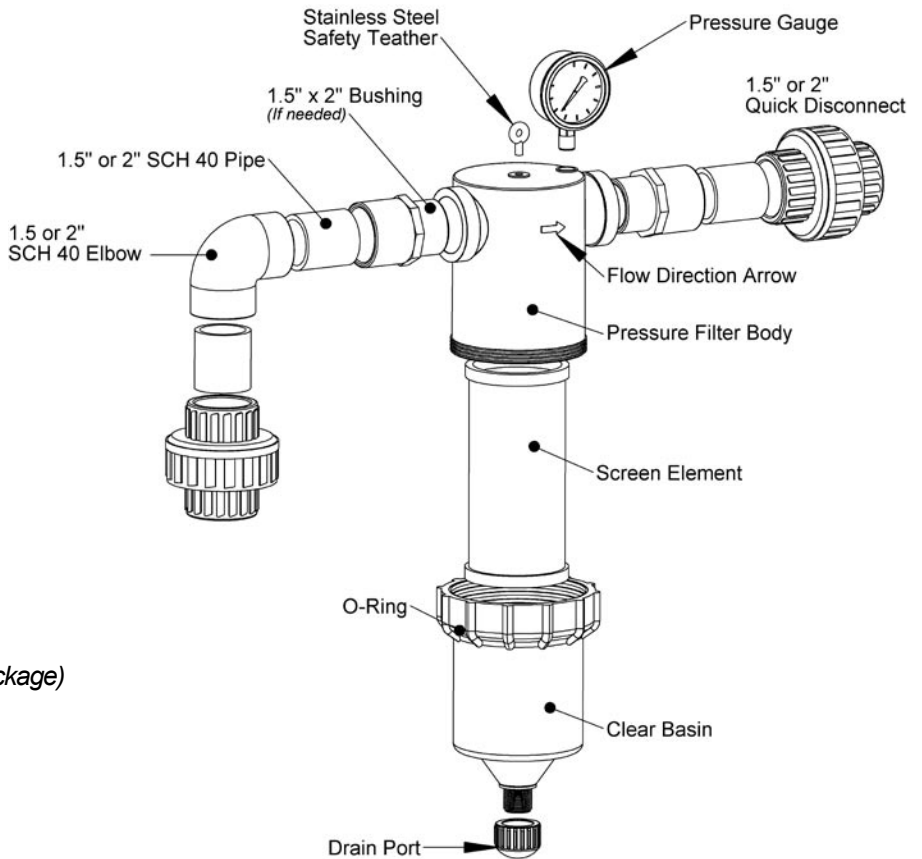

PDS-PF-1.5, PDS-PF-2.0				
Dimensions	A	B	C	D
Inches:	13.28	5.93	2.96	8.21
Materials:				
Upper Body:	Black UV Stabilized, PVC			
Clear Basin:	Polycarbonate			
Screen:	Stainless Steel			
Gasket:	EPDM (Standard) or Viton (Chemical Resistant)			
Max Flow:	120 gallons per minute (GPM)			

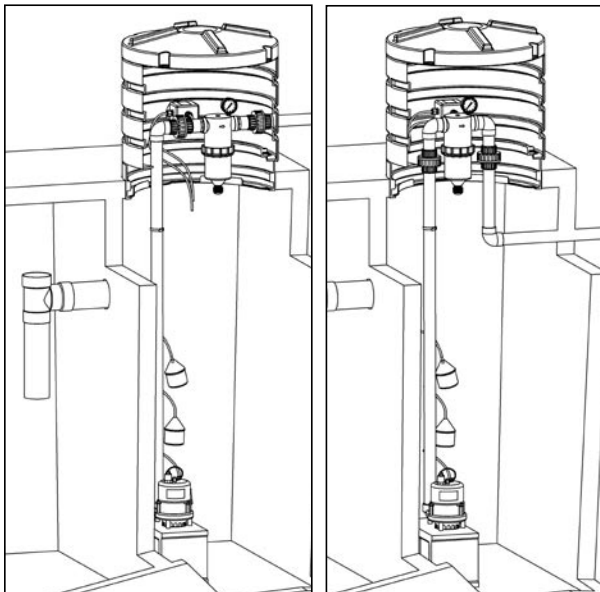

1-877-QUANICS - www.quanics.net



© 2006, Quanics Inc. All rights reserved.
Product(s) covered by one or more U.S.
and/or International patents. Other U.S.
and International patents may be pending.

